

DYNAMIC COMPONENT OVERHAUL

The Airwork Dynamic Component Overhaul division is NZCAA Part 145 certified and approved by Transport Canada.

We are specialists in BK117, AS350 / AS355, MD500 and B206 components.

Airwork NZ is an Accredited Eurocopter overhaul facility and Kawasaki Service Centre.



BK117



MD500



B206



AS350 / 355

Dynamic Component Overhaul Manager
Ian Frazer Tel: +64 9 295 2145 Email: ianf@airwork.co.nz

www.airwork.co.nz



DYNAMIC COMPONENT OVERVIEW

Complete Inspection, Repair and Overhaul of Dynamic Components – Eurocopter Approved Test Bench – Rental Units Available

The Airwork NZ Dynamic Component Overhaul division is certified under NZCCA Part 145 and is approved by Transport Canada.



Airwork NZ Dynamic Component division are specialists in inspection, repair and overhaul of Dynamic Components for:

- » AS350 / 355
- » BK117
- » B206
- » MD500



Airwork NZ Dynamic Component division offers:

- » Full technical field support:
- » Loan components, rental modules and accessories
- » Eurocopter approved test bench
- » BK117 Dynamic Component Test Bench





AS350 / 355 Test Bench

Airwork NZ Dynamic Component division is equipped with a Eurocopter Approved Dynamic Component Test Bench, which is used to test components after repair and overhaul. This state of the art technology enables us to deliver a quality component with complete quality assurance.



BK117 Dynamic Component Test Bench

As part of our commitment to quality control, Airwork NZ has a BK117 Dynamic Component Test Bench.





EUROCOPTER AS350 / AS355 DYNAMIC COMPONENTS

Airwork NZ offers comprehensive services for the inspection, repair and overhaul of all AS350 / 355 Dynamic Components



- » Tail Rotor Gear Box
- » Tail Rotor Pitch Change Assembly
- » Main Transmissions
- » Oil Pumps
- » Combiner Boxes
- » Epicyclic Assembly
- » Mast Assemblies
- » Hydraulic Pump Pully
- » Skid Dampers

Test Bench

Airwork NZ offers Eurocopter approved Dynamic Component overhauls tested on our Eurocopter Approved Test Bench.





Rentals & Accessories

We have an exchange pool of accessories, and also offer rental units.

Parts

A wide range of OEM inventory parts is available.

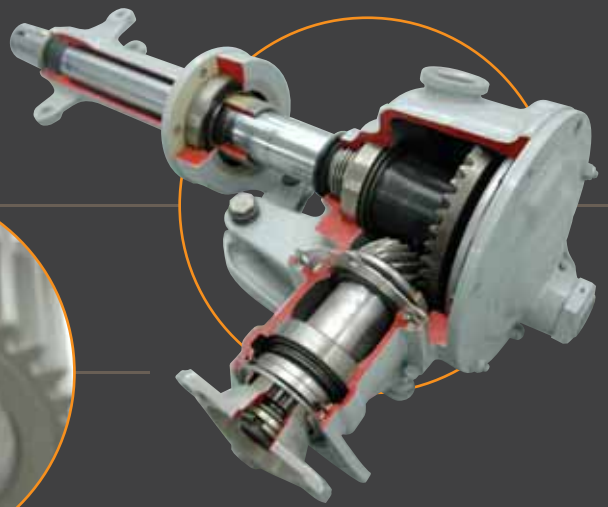



BK117 DYNAMIC COMPONENTS

Airwork NZ offers comprehensive services for the inspection, repair and overhaul of BK117 Dynamic Components:

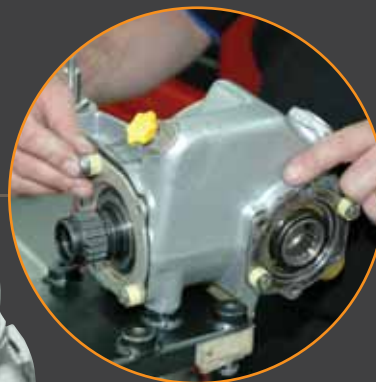

- » Main Transmission
- » Intermediate Gear Box
- » Tail Rotor Gear Box
- » Tail Rotor Pitch Change Assembly
- » Tail Rotor Pitch Change Link Bearing
- » Tail Rotor Head
- » Main Rotor Head
- » M/R Swash Plate
- » Mast Spacer Inspection



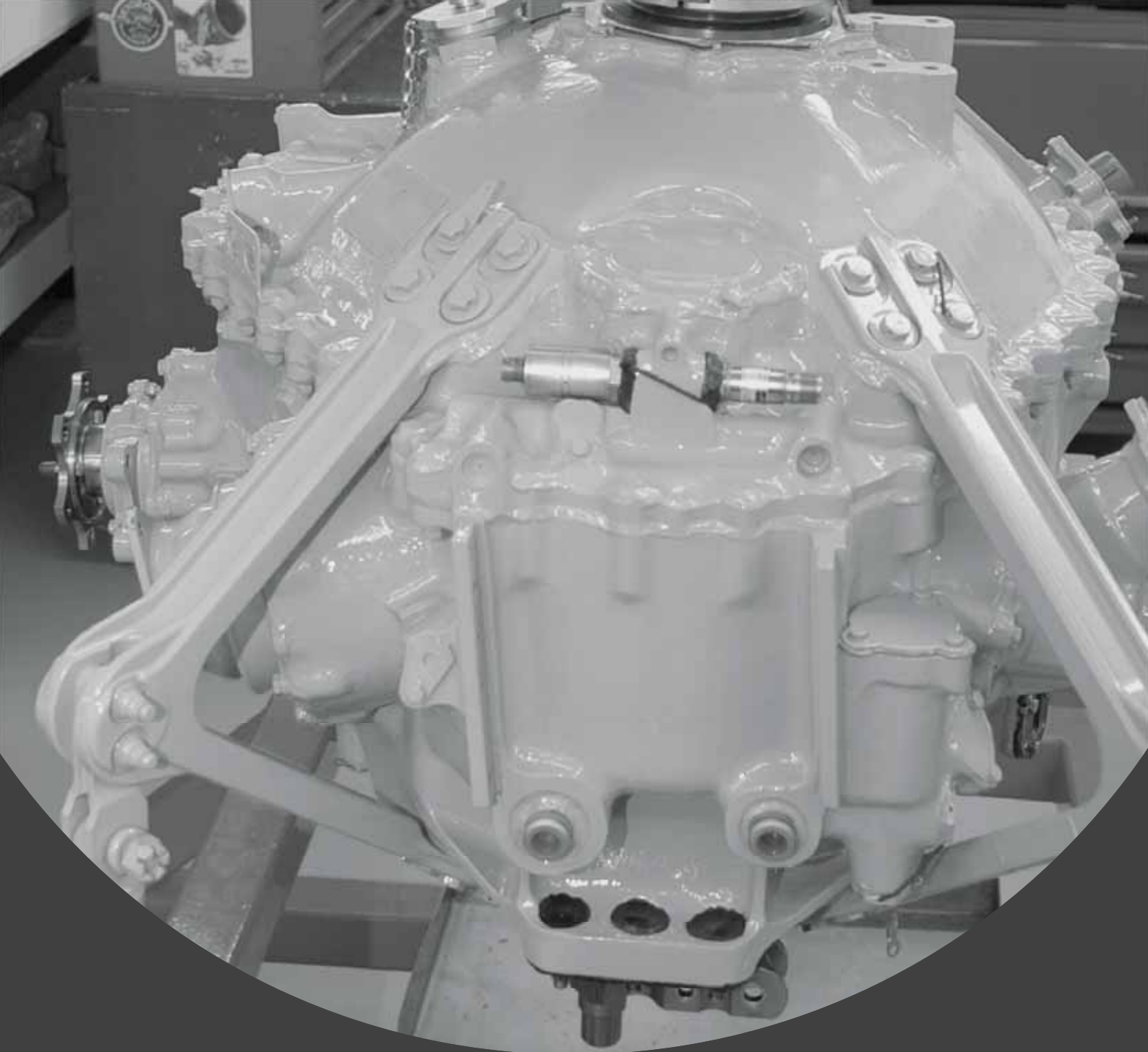

Test Bench

Airwork NZ offers BK117 Dynamic Component overhauls tested on our BK117 Test Bench.

Accessories

We have an exchange pool of accessories, and also offer rental components.

Parts

A wide range of BK117 OEM inventory parts is available.



Airwork NZ Limited is based in Auckland and has maintenance facilities at Ardmore Airfield, Mechanics Bay, New Plymouth, Wellington, Timaru, Glentanner, Queenstown, Christchurch and Brisbane airports.

In addition to our Dynamic Components Overhaul division, Airwork NZ Limited offers Manufacturing & Ancillary Workshops, Engineering, Turbine Overhaul and Parts Supply. Contact us today to discuss your engineering and maintenance requirements.

NZCCA – Approvals held: Part 141, 145, 146, 148, 19F

Manufacturing & Ancillary Workshops

Contact: John Simcox,

Tel: +64 9 295 2127

- Part 146 Design, Part 148 Manufacturing and Part 145 Maintenance certifications
- Breeze Eastern Service Centre

Design and Manufacture

- In-house design and manufacture of a range of modification packages, STC's and PMA items
- TIG Welding specialists
- CNC Machining
- Metal Arc Spraying
- Light Fabrication
- CAD Drawing

Workshops

- Electrical
- Avionics
- Instruments

Hoist Overhaul

- Hoist Test Rig audited and approved by Breeze Eastern

Non-Destructive Testing

Turbine Support Services

Contact: Clive Rankin,

Tel: +64 9 925 3171

- Part 145 certification
- Honeywell Approved Service Centre
- Approved by Transport Canada

Major Maintenance and Repair of:

- Honeywell LTS101
- Rolls Royce Allison 250
- Garrett TPE 331

Services

- Engine Test Cell
- Full technical field support
- OEM and PMA Warranty Support
- Extensive Inventory of OEM Parts
- Loan Engines, Rental Modules and Accessories

Parts Supply

Contact: Navin Raju,

Tel. +64 9 295 2132

- Part 19F certification
- Supplier of all aviation parts and needs

Dynamic Component Overhaul

Contact: Ian Frazer,

Tel: +64 9 295 2145

- Part 145 certification
- Approved by Transport Canada
- Accredited Eurocopter Overhaul Facility
- Kawasaki Service Centre
- Eurocopter Approved Test Bench
- BK117 Test Bench

Inspection, repair and overhaul of Dynamic Components for:

- BK117
- AS350 / AS355
- MD500
- B206

Services

- Full technical field support
- MRH 3 year/5 year Inspection
- Mast Spacer Inspection (on site or at your facility)
- Mast Assemblies
- T/R P/C Assembly Overhaul
- T/R P/C Link Bearing Replacement
- Main Transmission
- Tail Rotor Gearbox
- Intermediate Gearbox
- Oil Pump
- Skid Dampers
- Exchange pool of accessories, rental components and wide inventory of parts available

Helicopter Maintenance

Contact: Jeff O'Sullivan,

Tel: +64 9 295 2139

- Part 141 and Part 145 certifications
- Maintenance and Maintenance Control services

Fixed Base or Remote Servicing of the following aircraft:

BK117, AS355, H500, AS350, EC120, B206, AS365, MD500, B222

We have bases throughout New Zealand and Australia and also offer Global Surge Engineering teams to carryout maintenance at your facility.

Custom Fits, Role Changes, Refits & Refurbishment

- EMS
- Police
- Corporate
- Agricultural
- Tourism

Maintenance Control

- Forecasting
- Cost Analysis
- Control
- C of A's

Services & Inspections

- 12 yearly airframe overhauls
- Tail Boom repairs
- 1800, 2400 and 3600 hour inspections
- Lead lag inspections and Chadwick 8500
- Major and Minor Structural Repairs
- IFR Installations